

## SPECIFICATIONS

DESCRIPTION		UNIT	HT50A	HT65A
Rated Operating Capacity		Kg	780	940
Tipping Load		Kg	1560	1880
Operating Weight		Kg	2750	2950
Model			490BPG	804C-33
Make			Xinchai	Perkins
Gross Output		HP(kW)	49.6(37)	64.3(48)
ENGINE	Net Output	HP(kW)	62.7(46.8)	48.4(36)
	Engine Size	L	2.5	3.3
	Rated Speed	Rpm	2650	2500
	Cooling		Water	Water
GENERAL	Steering Controls		2 Levers	2 Levers
	Loader Controls		1 Pedal	1 Pedal
	Tyres Standard		10-16.5	10-16.5
	Max. Travel Speed	Km/h	11.4	11.4
HYDRAULIC	Hydraulic aux. flow	l/min	66.2	66.2
	Relief Pressure	Bar	180	180
A	Length With Bucket	mm	3270	3345
B	Height To Cab Top	mm	1983	1983
C	Wheel Base	mm	991	1020
D	Ground Clearance	mm	201	201
E	Overall Operating Height	mm	3906	4056
F	Height To Bucket Pivot Pin	mm	2996	3067
G	Max. Dump Height	mm	2264	2304
H	Reach At Max. Dump	mm	642	642
I	Forward Tilt Angle		30°	30°
K	Length w/o bucket		2605	2655
L	Departure Angle		16°	16°
J	Back Angle at Max. Height		99°	99°
O	Overall Width	mm	1740	1740
N	Bucket Width	mm	1760	1800
	Bucket Cap Heaped	m³	0.35	0.41
	Bucket Cap Struck	m³	0.27	0.32
	Fuel Tank Capacity	ℓ	58.6	58.6
	Hydraulic System Capacity	ℓ	58.6	58.6

## IMPORTED BY: SKIDLOADERS

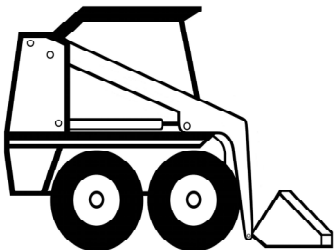

240 Birch Rd (M32), Petit  
1512, Benoni  
Tel: 079 841 1608  
Fax: 086 671 2173  
Cell: 083 461 3609  
Wilfried Smekens

## DIMENSIONS

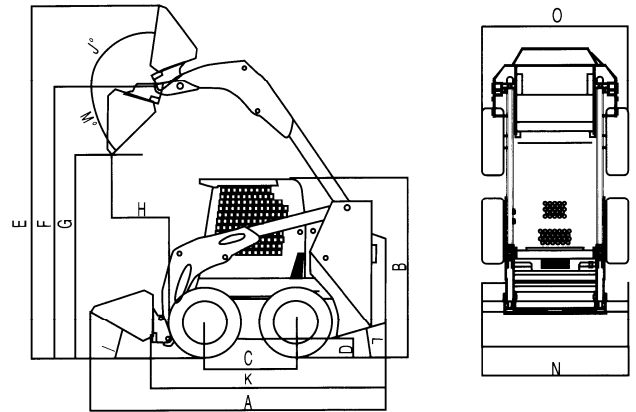

## STANDARD EQUIPMENT

- Standard bucket
- Operator safety bar
- Seat belt
- Engine cut out on cab exit
- Lift & bucket cylinder controls
  - 2 Lever for travel
  - 1 Pedal for attachment
- Hand & foot engine speed control
- Safety lock for hydraulics
- Boom lock safety bar
- Cab lock safety bar
- Working lights, 2 Front, 1 Rear
- Auxiliary hydraulic piping
- Lockable fuel & hydraulic filter cap
- ROPS/Fops Canopy
- Dust pre cleaner - spinner

## OPTIONAL EQUIPMENT

- Hydraulic oil temperature
- Room lamp
- Cigarette lighter
- Spark arresting muffler
- Enclosed cabin
- Heater
- Wiper
- Air conditioner
- Fender & rear view mirrors
- Engine overheat cut out
- Rotating/strobe light
- Reverse alarm

## INSTRUMENTATION

- Fuel level gauge
- Water temperature gauge
- Charging current gauge
- Light switch
- Battery disconnect relay switch
- Oil pressure warning light